



KIESELMANN
FLUID PROCESS GROUP

Operating instruction

- Translation of the original -

GEMBRA

Aseptic single seat tank outlet valve

Type: 5850



KIESELMANN GmbH

Paul-Kieselmann-Str.4-10
D - 75438 Knittlingen

☎ +49 (0) 7043 371-0 • Fax: +49 (0) 7043 371-125
www.kieselmann.de • sales@kieselmann.de

1. List of contents

1.	List of contents	1
2.	Information for your safety.....	2
3.	Marking of security instructions in the operating manual	2
4.	Safety instructions	3
4.1	Field of application	3
4.2	General safety instructions	3
4.3	General notes	3
5.	Function	4
5.1	Functional description	4
6.	Installation informations.....	4
6.1	Installation instructions.....	4
6.2	Welding guidelines	4
7.	Maintenance.....	4
7.1	Maintenance	4
7.2	Cleaning.....	4
8.	Technical data	5
9.	Control system - and interrogation system.....	5
9.1	Special features valve control -optional-	5
9.2	Proximity switch receiver set -optional-.....	5
10.	Pneumatic valve actuation	6
10.1	Actuator: air open - spring close (Lö - Fs).....	6
11.	Disassembly and assembly.....	7
11.1	Disassembly valve insert VE.....	7
11.2	Montage	7
11.3	Assemble the valve insert (VE) into the valve housing (VG).....	8
12.	Dimensions	9
13.	Drawing	10
14.	Manufacturing	12
14.1	Structure of Article number	12
14.2	Interrogation system	12
15.	Spare parts list	13
16.	Aseptic tank outlet valve Type: 5850 (1.4404 / AISI316L)	13
16.1	Valve insert	13
16.2	Seal kit k-flex/EPDM	14
17.	Declaration of incorporation	15

2. Information for your safety

We are pleased that you have decided for a high-class KIESELMANN product. With correct application and adequate maintenance, our products provide long time and reliable operation.



Before installation and initiation, please carefully read this instruction manual and the security advices contained in it. This guarantees reliable and safe operation of this product and your plant respectively. Please note that an incorrect application of the process components may lead to great material damages and personal injury.

In case of damages caused by non observance of this instruction manual, incorrect initiation, handling or external interference, guarantee and warranty will lapse!

Our products are produced, mounted and tested with high diligence. However, if there is still a reason for complaint, we will naturally try to give you entire satisfaction within the scope of our warranty. We will be at your disposal also after expiration of the warranty. In addition, you will also find all necessary instructions and spare part data for maintenance in this instruction manual. If you don't want to carry out the maintenance by yourself, our KIESELMANN service team will naturally be at your disposal.

3. Marking of security instructions in the operating manual

Hints are available in the chapter "safety instructions" or directly before the respective operation instruction. The hints are highlighted with a danger symbol and a signal word. Texts beside these symbols have to be read and adhered to by all means. Please continue with the text and with the handling at the valve only afterwards.

Symbol	Signal word	Meaning
	DANGER	Imminent danger which may cause severe personal injury or death.
	ATTENTION	Dangerous situation which may cause slight personal injury or material damages.
	NOTE	Marks application hints and other information which is particularly useful.

4. Safety instructions

4.1 Field of application

The valve is utilised as a pneumatically controlled shut-off valve in food and beverage as well as in pharmaceutical, biotechnological and chemical industries.

The valve is designed for media characteristics according to article 9 of DGRL 97/23/EG for group 2 (media condition gaseous or liquid).



ATTENTION

- To avoid danger and damage, the fitting must be used in accordance with the safety instructions and technical data contained in the operating instructions.

4.2 General safety instructions



DANGER

- Danger of crushing or amputating limbs.
Do not reach into the valve housing when in pneumatic mode.
- When removing the valve or valve components from the system, there is a danger of injury from escaping liquids or gases.
Only dismantle when you are absolutely sure that the system is depressurized and free of liquids and gases.
- Danger of scalding and burns to parts of your body from liquids escaping from the leakage drain (L) (Fig. 7 /Page 10).
The splash protection fixtures must always be attached to the leakage drain (L).
- The actuation can be dismantled.
Danger of injury by prestressed pressurespring. Observe separate installation instructions.
- We recommend having the manufacturer do the maintenance work required for the actuation.



ATTENTION

- When dismantling the clamp coupling the spring pre-stressed valve insert can cause injury due to a lifting movement in the "X" direction (Fig. 7 /Page 10).
First open valve pneumatically, then unscrew the clamp coupling.
- To avoid air leaking, only use pneumatic connection parts that have an O-ring seal facing the even surface.
- When mounting the clamps, the max. torque must not be exceeded (see technical Data).
- Steps should be taken to ensure that no external forces are exerted on the fitting.

4.3 General notes



NOTE

- All data are in line with the current state of development. Subject to change as a result of technical progress.

5. Function

5.1 Functional description

The valve is utilised as a pneumatically controlled shut-off valve. Leakage detection takes place via the leakage outlet (L) at the lantern.



Fig. 1

➤ Actuator: air open - spring close

The valve opens with control air and closes with spring power by means of a lift drive.

6. Installation informations

6.1 Installation instructions

The valve must be installed vertically with the actuator at the upwards. Liquid must be able to flow freely from the valve housing. A releasable connection has to be fitted into the pipework to allow dismantling/maintenance. In order to obviate damages, the integration of the pipeline has to be carried out without stress.

6.2 Welding guidelines

- Sealing elements integrated in weld components must generally be removed prior to welding.
- To prevent damage, welding should be undertaken by certified personnel (EN287).
- Use the TIG (tungsten inert gas) welding process.



NOTE

Impurities can cause damage to the seals. Clean inside areas prior to assembly.

7. Maintenance

7.1 Maintenance

The maintenance intervals depend on the operating conditions:

- temperature, temperature-intervals
- medium and cleaning medium
- pressure
- opening frequency

We recommend replacing the seals every 2 years. The user, however should establish appropriate maintenance intervals according to the condition of the seals.



NOTE

EPDM; Viton; K-flex; NBR; HNBR
Silicone
Thread

⇒
⇒
⇒

Lubricant recommendation

Klüber Paraliq GTE703*
Klüber Sintheso pro AA2*
Interflon Food*

*)It is only permitted to use approved lubricants, if the respective fitting is used for the production of food or drink. Please observe the relevant safety data sheets of the manufacturers of lubricants.

7.2 Cleaning

The upper and lower process housing is cleaned via pipeline cleaning.

8. Technical data

Model:	Tank outlet valve	
Valve size:	DN 40 - 80 DN 1½ INCH - 3 INCH	
Connection:	Welding end DIN11850 serie 2	
Temperature range:	Ambient temperature: +4° to +45°C Product temperature: +0° to +95°C medium-dependent Sterilization temperature: +140°C short time (30min)	
Operatins pressure:	DN 40 - DN 65 = max. 10 bar DN 1½ INCH - DN 2½ INCH = max. 10 bar DN 80 / DN 3 INCH = max. 8 bar	
Cleaning pressure:	3 bar	
Pressure resistance:	30 bar	
Vacuum:	1,5 - 10 ⁻⁶ mbar x 1/5 (test pressure 0,5mbar)	
Control air pressure:	5,5 - 8,0 bar	
Quality of control air:	ISO 8573-1 : 2001 quality class 3	
Material:	in product contact	not in product contact
Stainless steel:	1.4404 / AISI316L	1.4301 / AISI304
Surfaces:	RA ≤0,8µm e-pol.	metallic bright, e-pol.
Seals:	k-flex (FDA) 150°C EPDM (FDA) 140°C PTFE	EPDM

Retaining clamp: Dimension nominal

DN 25 1INCH	DN 40 1½INCH	DN 50 2INCH	DN 65 2½INCH	DN 80 3INCH	DN 100 4INCH
-	15	15	25	20	-

Tightening moment:

Torque in Nm

9. Control system - and interrogation system

9.1 Special features valve control -optional-

Optionally, modular valve control systems can be installed to the actuator for reading and actuating valve positions. The standard version is a closed system with SPS or ASI-bus switch-on electronics, and integrated 3/2-way solenoid valves. For tough operating conditions we recommend employing a high-grade steel cover.

9.2 Proximity switch receiver set -optional-

For the acquisition of the valve positions over inductive initiators, a limit switch support is mounted on the actuation. The enquiry takes place over the position of the piston rod.

10. Pneumatic valve actuation

10.1 Actuator: air open - spring close (Lö - Fs)

Valve function	pneumatic Control with MV in Control unit (Fig. 2 /Page 6)	pneumatic Control with external solenoid valve (Fig. 2 /Page 6)
Valve "OPEN"	control air feed P → MV1 → P1/LA2 Valve is opening by control air	control air feed ext. MV → LA2 Valve is opening by control air
Valve "CLOSED"	de-aeration LA2/P1 → MV1 → R Valve is closing by spring	de-aeration LA2 → ext. MV Valve is closing by spring

MV = Solenoid valve
 R = de-aeration, sound absorber
 P = compressed-air inlet (control unit)
 LA2 = compressed air inlet (actuation)
 S = slide switch - manual control (solenoid valves)

 I = Initiatoren
 H = Angle bracket
 E = de-aeration
 LA2 = Air connection

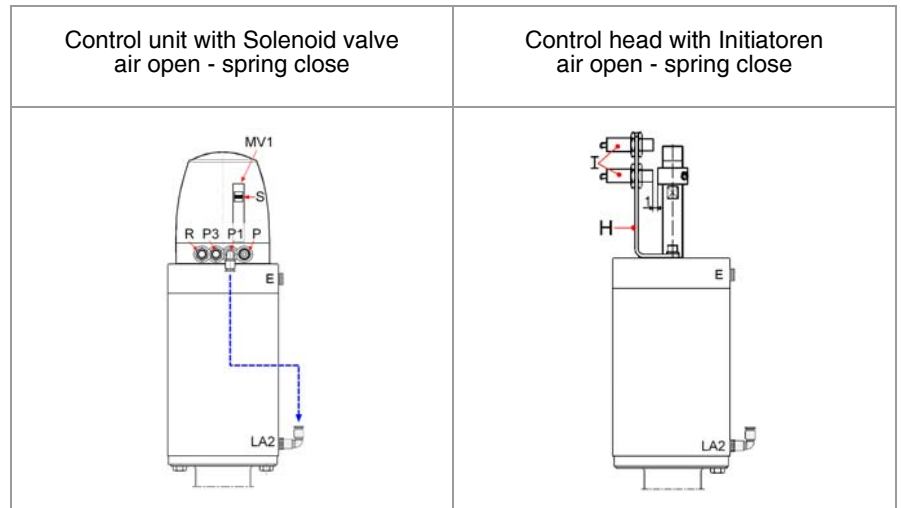

Fig. 2

11. Disassembly and assembly

(see Fig. 7 /Page 10) **11.1 Disassembly valve insert VE**



NOTE

Dismount control air, steam, condensate pipelines and electric lines, complete proximity switch mounting or control heads.

- Connect the compressed air (P) to the air connection (LA2) thereby the piston moves toward X.
- Remove retaining clamp (VK) and pull out carefully and without rotary movement the valve insert from the valve housing (VG).

Wrench size					
SW	1	2	3	4	B
DN40	19	27	17	17	ø7
DN50	19	27	17	17	ø7
DN65	19	24	17	17	ø7
DN80	27	30	17	17	ø8

➤ Exchanging seals [A] Item (D2), (D3), (D4)

- Screw off piston plate (1) while holding against at the wrench size (SW2).
- Dismount sealing (D1) and (D6).
- Screw off piston (2) at the wrench size (SW2), while holding against with round rod at drilling (B).
- Take off carefully the diaphragm (D2) from the upper piston (3) and the lantern (4).
- Screw off locking screw (6).
- Loosen hexagon screws (8) and pull off lantern (4).
- Dismount plain bearing (D3) and O-Ring (D4).
- Replace the seals and the wear parts.

➤ Exchanging seals [B] Item (D5)

- see 'exchanging seals [A]'.
- Screw off the thread connection (G1) of the piston rod (7) and the spindle (10) at the spanner surfaces and axially remove it out of the actuator (9).
- Replace the O-Rings (D5).

➤ Exchanging seals [C] Item (D7)

- Dismount the tube connection at the housing (VG).
- Unscrew the screws (16).
-
- Dismount the housing (VG) and flange (15).
- Replace the O-Ring (D7).

11.2 Montage

- Thoroughly clean and slightly lubricate mounting areas and running surfaces.
- Assemble in reverse order.



NOTE

During assembly, tie diaphragm (D2) carefully on lantern (4) and on the upper piston (3) (Fig. 3/Page 7). Assemble the thread connections "A" with removable screw retention (e.g. Loctite 243).

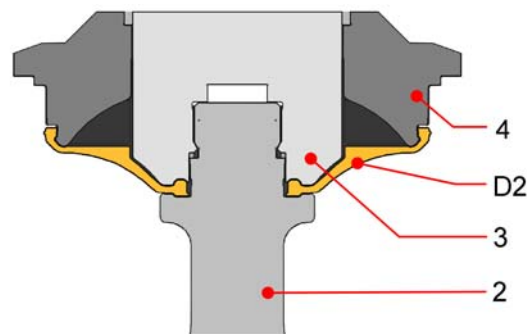

Fig. 3

11.3 Assemble the valve insert (VE) into the valve housing (VG)

► Adjust the installation position of the piston with the mounting tool (MW)

MW



Mounting tool MW for GEMBRA Single seat valves	
DN40 - DN65	Art.-No.: 5836 000 065-000
DN80	Art.-No.: 5836 000 080-000

Kind of actuator: air open - spring close

- Connect the compressed air (P) to the air connection (LA2) thereby the piston moves toward X.
- Unscrew the cap (13).
- Screw in the mounting tool (MW) as far as possible into the spindle (10).
- Disconnect the compressed air (P) from the air connection (LA2) thereby the valve drives into installation position.



NOTE

In this valve position the diaphragm (D2) is in its basic position and is optimally compressed between lantern and housing.

► Adjust the installation position of the piston without the mounting tool (MW)

- Connect compressed air (P) to the throttle valve (LA2) thereby according to kind of the actuator the piston drives in.
- Close the throttle valve at (LA2) with a screwdriver.
- Disconnect the compressed air at the throttle valve (LA2).
- The piston stops in the position. Position a calliper on the adjustment dimension M1 or M2.
- Slowly open the throttle valve at (LA2), so that the piston drive out.
- Close the throttle at the position M1 respectively M2. (If an control head is assembled, the adjustment dimension M1 is measured between the actuator and the pin (8).

	Bore	adjustment dimension for the installation position		
	B	M1	M2 ^a	M3 ^b
DN40	ø7	18,5	107	96
DN50	ø7	18,5	107	96
DN65	ø8	29	104	93
DN80	ø8	35	98	87

a. old version
b. new version



NOTE

In this valve position the diaphragm (D2) is in its basic position and is optimally compressed between lantern and housing.

Assemble the valve insert into the valve housing

- Carefully install the valve insert in the housing.



NOTE

When installing the valve seat, do not damage the sealing surfaces on the piston and the housing as well as the seals.

- Assemble the retaining clamp (VK) (Please note the torque data! See the tightening moment in technical data).
- Slowly open the throttle valve again. The piston drives into its basic position.
- Check the valve functions.

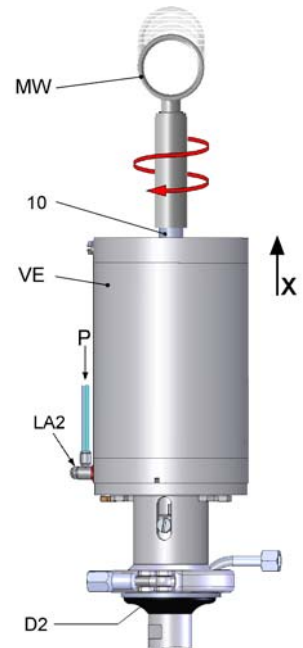

Actuator: lö-fs Fig. 4

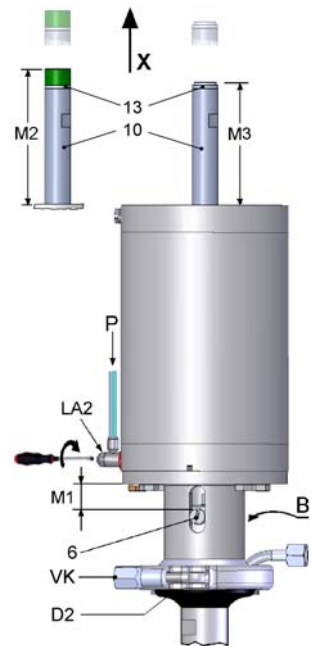

Actuator: lö-fs Fig. 5

12. Dimensions

Dimension nominal	DN40 1½INCH	DN50 2INCH	DN65 2½INCH	DN80 3INCH
d1	∅ 41x1,5 ∅ 38,1x1,65	∅ 53x1,5 ∅ 50,8x1,65	∅ 70x2 ∅ 63,5x1,65	∅ 85x2 ∅ 76,2x1,65
d2	∅ 129	∅ 129	∅ 167	∅ 167
d3	∅ 125	∅ 138	∅ 165	∅ 176
d4	∅ 133	∅ 146	∅ 173	∅ 186
L1	430	437	507	536
L2	46,5	45,5	55	74
L3	85	85	110	115
L4	170	170	220	230
L5	92	92	102	107
L6	3	3	3	3
L7	29	29	29	33
G1	1/4	1/4	1/4	1/4
M*	580	590	680	755
Valve stroke	18	18	20	27

Measure in mm

*) Size when completed (with control head)

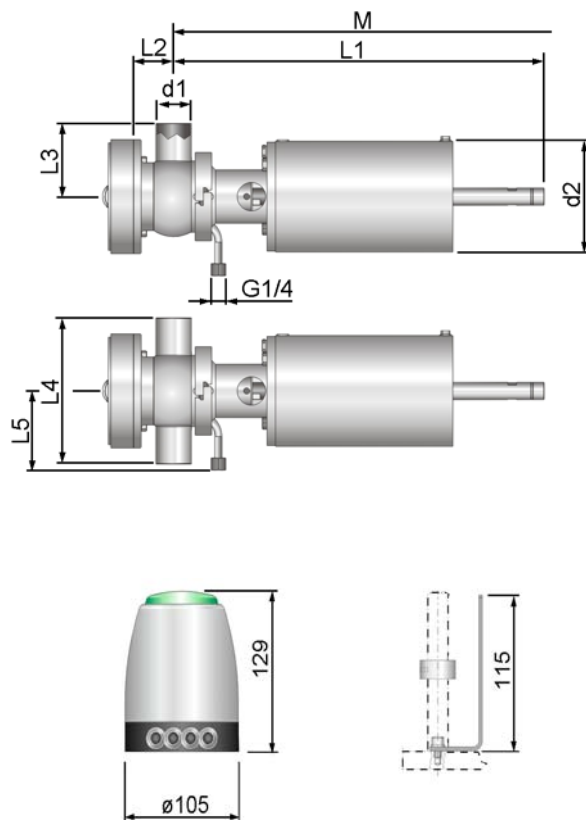

➤ Flange (FI) Art.-no.: 5727 DN 001-040

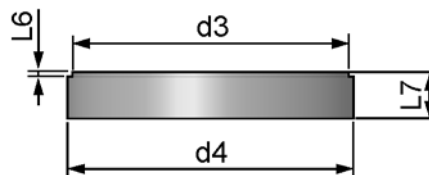

Fig. 6

13. Drawing

► GEMBRA Aseptic tank outlet valve Type: 5850

- 15 = Flange
- 16 = Retaining ring
- 17 = Screw

- A1 = Control head
- A2 = Sensor mounting
- D7 = O-Ring
- Fl = Flange (not included in delivery)
- L = Leakage tell tauw G1/4
- LA1 = air open-spring close - De-aeration
- LA2 = air open-spring close - Valve stroke
- VE = Valve insert
- VG = Valve housing
- L-design
- T-design
- VK = Retaining clamp
- P = Cental air supply
- P1 = Control air - Valve stroke

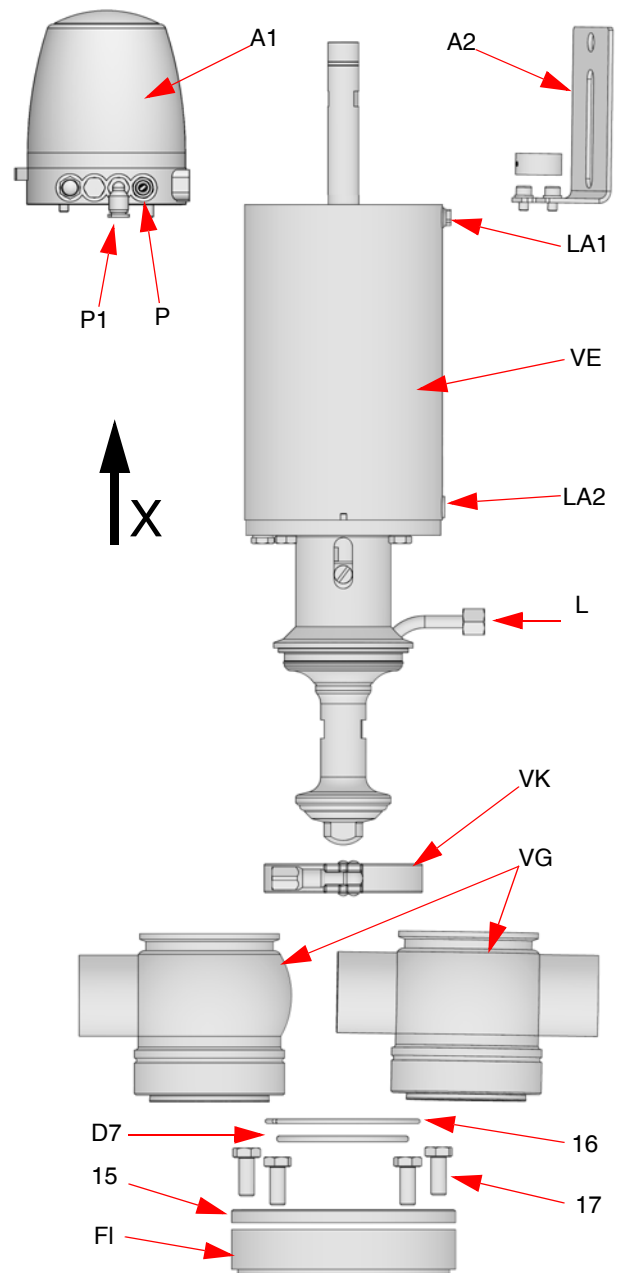

Fig. 7

➤ **Valve insert**

- 1) Piston plate lower
- 2) Piston lower
- 3) Piston upper
- 4) Lantern
- 5) Screw retention
- 6) Locking screw
- 7) Piston rod
- 8) Hexagon screw
- 9) Actuator
- 10) Spindle
- 11) O-Ring
- 12) Position indication
- 13) Cap
- 14) Distance (DN65)

- D1) Seal
- D2) Diaphragm
- D3) Plain bearing
- D4) O-Ring
- D5) O-Ring
- D6) Seal washer

- B1 = Bore
- G1 = Threat connection secured with Lock nut removable (e.g. Loctite 243)
- IP = Pulse generator (only required by use of a KIESELMANN control head)
- L = Leakage tell taue G1/4

➤ **Wrench size**

	SW1	SW2	SW3	SW4	B1
DN40/1½ INCH	19	27	17	17	ø7
DN50/2 INCH	19	27	17	17	ø7
DN65/2½ INCH	19	24	17	17	ø7
DN80/3 INCH	27	30	17	17	ø8

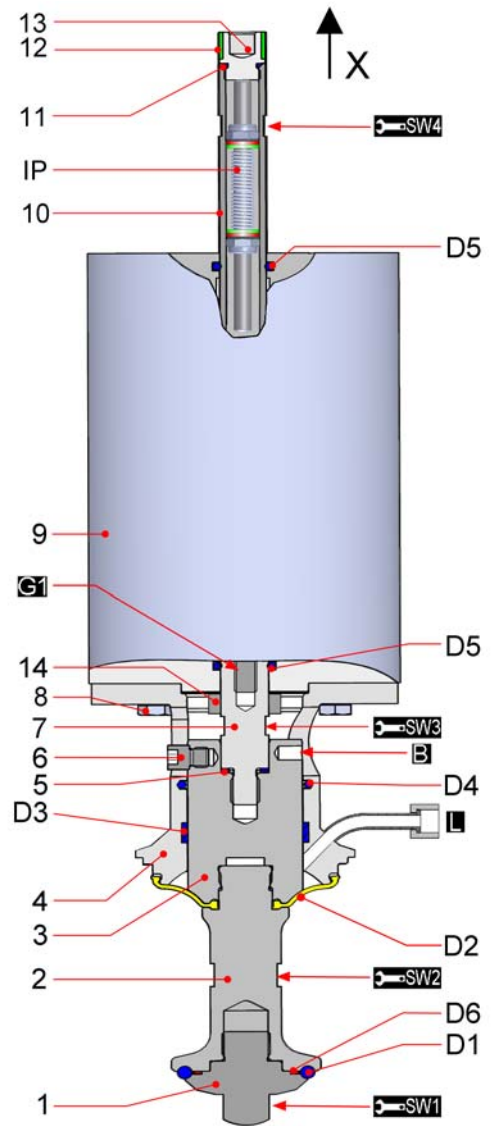
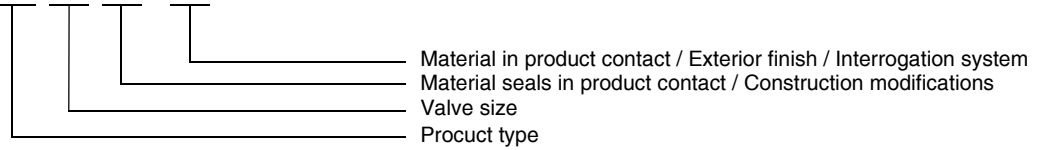

Fig. 8

14. Manufacturing

14.1 Structure of Article number

5850 050 000 - 041



➤ Product type

5850 = GEMBRA-Aseptic tank outlet valve

➤ Valve type

DN = Nominal diameter

DIN	025 = DN25	040 = DN40	050 = DN50	065 = DN65	080 = DN80
INCH	026 = DN1	038 = DN1½	051 = DN2	064 = DN2½	076 = DN3

➤ Material seal / Construction modifications

Material seals in product contact: k-flex, PTFE

Construction modifications: Housing design

L-design

T-design



➤ Material in product contact / Exterior finish

020 - 1.4301/1.4307 AISI304/307 - bright turned	040 - 1.4301/1.4307 AISI304/307 - bright turned
021 - 1.4301/1.4307 AISI304/307 - E-polished	041 - 1.4301/1.4307 AISI304/307 - E-polished
022 - 1.4301/1.4307 AISI304/307 - unpolished, glass-bead blasted	042 - 1.4301/1.4307 AISI304/307 - unpolished, glass-bead blasted

14.2 Interrogation system

Article number	Control System or Interrogation System (A1, A2)
58xx DN xxx -041	Valve without Control- or Interrogation System
58xx DN xxx -750	Valve with Sensor mounting set (5630 005 000-020)
58xx DN xxx -6xx	Control head ASi-Bus for GEMBRA-Double seat valve
58xx DN xxx -K6xx	Control head KI-Top ASi-Bus for GEMBRA-Double seat valve
58xx DN xxx -5xx	Control head SPS for GEMBRA-Double seat valve
58xx DN xxx -K5xx	Control head KI-Top SPS for GEMBRA-Double seat valve

DN - nominal diameter e.g. 58xx 050 000-041

15. Spare parts list

16. Aseptic tank outlet valve Type: 5850 (1.4404 / AISI316L)

Housing	Seal	Actuator	Article-No.	Seal kit
L-Form	k-flex/EPDM	lö - fs	5850 DN 000-xxx	5850 DN 990-114
T-Form	k-flex/EPDM	lö - fs	5850 DN 200-xxx	5850 DN 990-114

Item	Designation	Material	DN25 1INCH	DN40 1½INCH	DN50 2INCH	DN65 2½INCH	DN80 3INCH	DN100 4INCH
VE	Valve insert lö - fs	k-flex	-	5850 040 020-041	5850 050 020-041	5850 065 020-041	5850 080 020-041	-
IP	Pulse generator ^a	-	-	5714 025 005-000	5714 025 005-000	5802 065 005-000	5702 065 005-000	-
VG	Housing L-design	-DIN -INCH AISI316L	-	5850 040 007-041	5850 050 007-041	5850 065 007-041	5850 080 007-041	-
	Housing T-design		-	5850 038 007-041	5850 051 007-041	5850 064 007-041	5850 076 007-041	-
			-	5850 040 207-041	5850 050 207-041	5850 065 207-041	5850 080 207-041	-
		-	5850 038 207-041	5850 051 207-041	5850 064 207-041	5850 076 207-041	-	
VK	Retaining clamp	AISI304	-	2122 065 100-020	2122 065 100-020	2122 115 100-020	2122 125 100-020	-
FI	Flange ^b	AISI316L	-	5727 040 001-040	5727 050 001-040	5727 065 001-040	5727 080 001-040	-
15	Flange	AISI316L	-	5727 040 004-041	5727 050 004-041	5727 065 004-041	5727 080 004-041	-
16	Retaining ring	AISI301	-	5727 040 003-031	5727 050 003-031	5727 065 003-031	5727 080 003-031	-
17	Screw (4x)	AISI304	-	8106 010 025-020	8106 010 025-020	8106 012 025-020	8106 012 035-020	-

DN = Dimension nominal e.g. 5850 050 000-041 = DN50 , 5850 051 000-041 = 2 INCH
xxx = Interrogationsystem
lö = air open
ls = air close
fö = spring open
fs = spring close

a. only required by use of a KIESELMANN control head)
b. not included in delivery

16.1 Valve insert

Nr.	Designation	Material	DN25 1INCH	DN40 1½INCH	DN50 2INCH	DN65 2½INCH	DN80 3INCH	DN100 4INCH
VE	Valve insert lö - fs	k-flex	-	5850 040 020-041	5850 050 020-041	5850 065 020-041	5850 080 020-041	-
1	Piston plate	AISI316L	-	5850 050 009-040	5850 050 009-040	5850 065 009-040	5850 080 009-040	-
2	Piston lower	AISI316L	-	5850 040 005-040	5850 040 005-040	5850 050 005-040	5850 080 005-040	-
3	Piston upper	AISI316L	-	5836 040 007-041	5836 040 007-041	5836 065 007-041	5836 080 007-041	-
4	Lantern	AISI304	-	5821 050 014-021	5821 050 014-021	5821 065 014-021	5821 080 014-021	-
5	Screw retention	AISI316L	-	8135 012 195-040	8135 012 195-040	8135 012 195-040	8135 012 195-040	-
6	Locking screw	AISI304	-	5836 040 008-020	5836 040 008-020	5836 040 008-020	5836 080 008-020	-
7	Piston rod	AISI303	-	5836 040 006-220	5836 040 006-220	5836 080 006-220	5836 080 006-220	-
8	Hexagon screw (4x)	AISI304	-	8106 008 020-020	8106 008 020-020	8106 008 020-020	8106 008 020-020	-
9	Actuator lö - fs	AISI304	-	52001 291 51-032	5200 129 151-032	5200 167 151-032	5200 167 151-032	-
10	Spindle	AISI303	-	5622 100 070-220	5622 100 070-220	5622 100 070-220	5622 100 070-220	-
11	O-Ring	EPDM	-	2304 012 020-170	2304 012 020-170	2304 012 020-170	2304 012 020-170	-
12	Position indication	ABS gn	-	5622 100 058-152	5622 100 058-152	5622 100 058-152	5622 100 058-152	-
13	Cap	AISI303	-	5622 100 071-220	5622 100 071-220	5622 100 071-220	5622 100 071-220	-
14	Distance (DN65)		-	-	-	5836 065 010-020	-	-

16.2 Seal kit k-flex/EPDM

Nr.	Designation	Material	DN25 1INCH	DN40 1½INCH	DN50 2INCH	DN65 2½INCH	DN80 3INCH	DN100 4INCH
	Seal kit	k-flex/EPDM	-	5850 040 990-114	5850 050 990-114	5850 065 990-114	5850 080 990-114	-
D1	O-Ring	k-flex	-	2304 045 060-114	2304 045 060-114	2304 060 060-114	2304 079 060-114	-
D2	Diaphragm	PTFE	-	5821 050 020-053	5821 050 020-053	5821 065 020-053	5821 080 020-053	-
D3	Plain bearing	KV	-	8051 250 010-081	8051 250 010-081	8051 190 010-081	8051 220 020-081	-
D4	O-Ring	EPDM	-	2304 049 035-170	2304 049 035-170	2304 062 035-159	2304 072 035-170	-
D5	O-Ringe (2x)	EPDM	-	2304 019 035-171	2304 019 035-171	2304 019 035-171	2304 019 035-171	-
D6	Seal washer	PTFE	-	2352 044 037-053	2352 044 037-053	2352 059 052-053	2352 078 071-053	-
D7	O-Ring	EPDM	-	2304 062 035-159	2304 075 040-054	2304 090 040-170	2304 102 050-159	-



Declaration of incorporation

Translation of the original

Manufacturer / authorised representative:

KIESELMANN GmbH
Paul-Kieselmann-Str. 4-10
75438 Knittlingen
Germany

Authorised representative,
for compiling technical documents:

Achim Kauselmann
KIESELMANN GmbH
Paul-Kieselmann-Str. 4-10
75438 Knittlingen
Germany

Product name

pneum. Lift actuators
pneum. Rotary actuators
Ball valves
Butterfly valves
Single seat valves
Flow control valves
Throttle valve
Overflow valve
Double seat valve
Bellow valves
Sampling valves
Two way valves
Tankdome fitting

Function

Stroke movement
Rotary movement
Media cutoff
Media cutoff
Media cutoff
Control of liquefied media
Control of liquefied media
Definition of fluid pressure
Media separation
Sampling of liquids
Sampling of liquids
Media cutoff
Prevention of overpressure and vacuum, Tank cleaning

The manufacturer hereby states that the above product is considered as an incomplete machine in the sense defined in the Directive 2006/42/EC on Machinery. The above product is exclusively intended to be installed into a machine or an incomplete machine. The said product does not yet conform to all the relevant requirements defined in the Directive on Machinery referred to above for this reason.

The specific technical documents listed in Appendix VII, Part B, have been prepared. The Authorized Agent empowered to compile technical documents may submit the relevant documents if such a request has been properly justified.

Commissioning of an incomplete machine may only be carried out if it has been determined that the respective machine into which the incomplete machine is to be installed conforms to the regulations set out in the Directive on Machinery referred to above.

The above product conforms to the requirements of the directives and harmonized standards specified below:

- DIN EN ISO 12100 Safety of machinery

Knittlingen, 09. 08. 2013

Klaus Dohle
General Director